

Purchasing Dept  
Copy

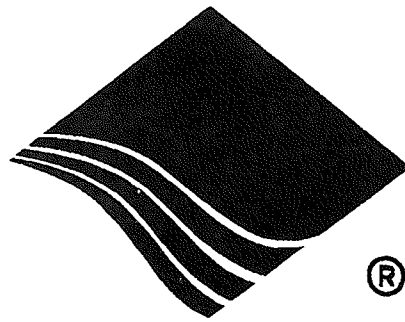

**HIGHLEAD**

**GM700 Series**

**HIGH-SPEED OVERLOCK SEWING MACHINE**

**Instruction Manual**

**Parts Catalog**

**SHANGHAI HUIGONG NO.3 SEWING MACHINE FACTORY**

From the library of: Superior Sewing Machine & Supply LLC



## — INTRODUCTION —

Thank you very much for purchasing 700 Series machine.

This instruction manual describes daily routine maintenance and safety precautions to keep the machine in the best possible conditions.

Please study this manual very carefully before operating the machine.



### CAUTION

#### OBSERVE THESE SAFETY PRECAUTIONS

Though Pegasus takes the utmost care to produce safe sewing machines and devices, operators should follow these basic safety rules.

- To prevent accidents, do not remove safety devices or parts while operating the machine.
- Do not leave tools or other unnecessary objects on the machine table while operating the machine.
- Before maintenance, adjusting, cleaning, threading or replacing the needle, and to prevent accidents, be sure the power is turned off. Check that the machine will not operate when the pedal is pressed.



### NOTE

In case a crutch type motor is used, it will keep on rotating by inertia after turning off power supply

①. If the machine pedal ② is stepped on inadvertently, it is dangerous because the machine will move unexpectedly. Keep on stepping on the machine pedal ② until the machine comes to a stop after turning off power supply ①.

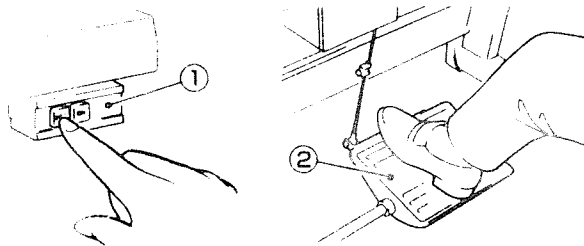

- Turn the power off before leaving the machine table.
- In the event of a power failure, be sure to turn the machine off.
- Check that the machine is securely grounded.

■ **BEFORE OPERATING**

1. Schematic diagram of the machine table ..... 1  
2. Installing the machine head ..... 2  
3. The machine speed and the turning direction ..... 3  
4. Lubrication ..... 4  
5. Manual lubrication ..... 5  
6. Filling the HR device with silicon oil ..... 6  
7. Threading ..... 7

■ **TEST SEWING**

1. Adjusting the presser foot pressure ..... 8  
2. Adjusting the diff. feed ratio ..... 9  
3. Adjusting the stitch length ..... 10  
4. Adjusting the thread tension ..... 11

■ **MAINTENANCE DURING USE**

1. Cleaning the machine ..... 12  
2. Replacing the needle ..... 13  
3. Checking the oil circulation ..... 14  
4. Replacing the oil ..... 15  
5. Replacing the lower knife ..... 16  
6. Adjusting dimensions ..... 17  
7. Standard needle Comparison table of equivalent sizes ..... 17

■ **PARTS CATALOG**

..... 18-25

■ BEFORE OPERATING

Schematic diagram of the machine table

Cut the table referring to the diagram

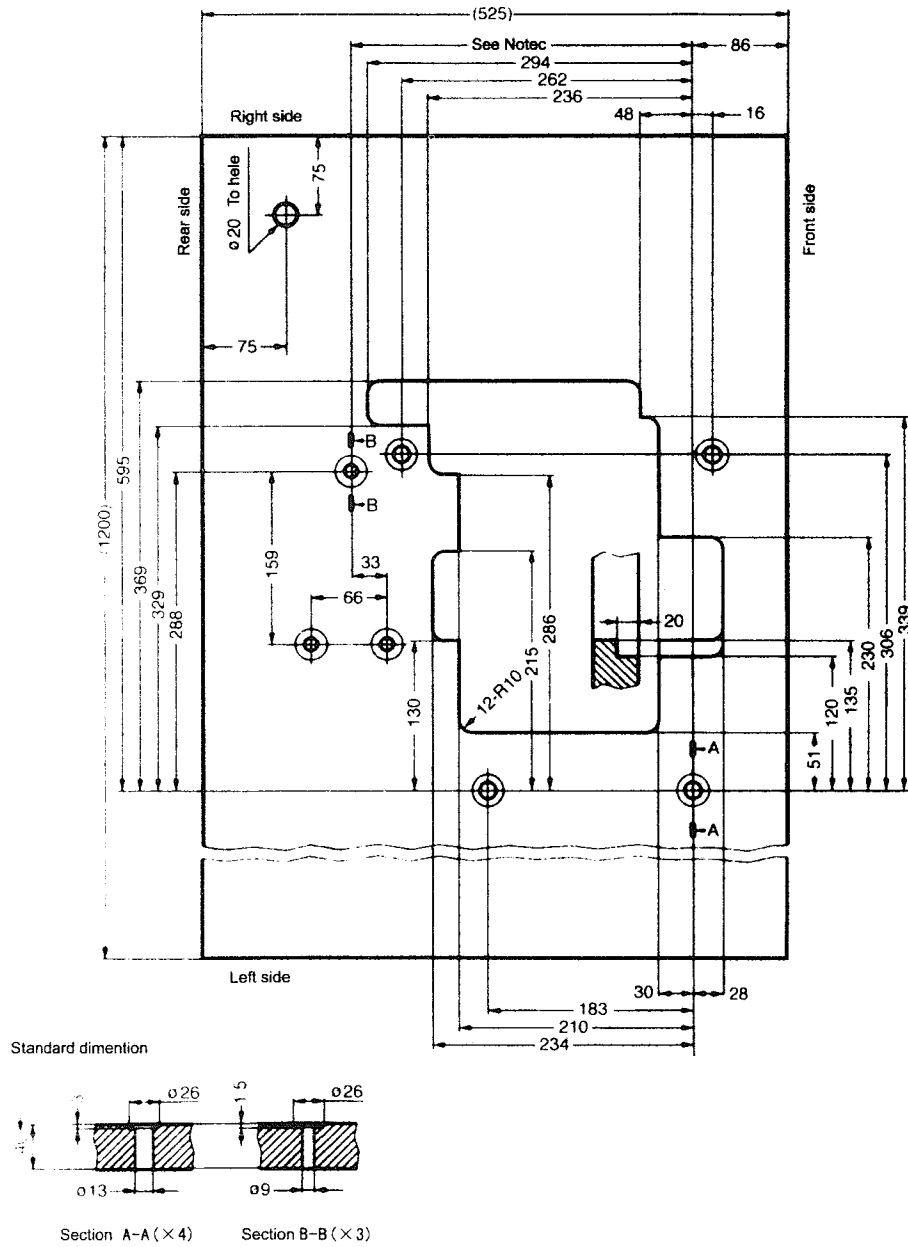

## ■ BEFORE OPERATING

### Installing the machine head

1. Mount the machine head on the machine rest board.
2. Install ground wire at PE.
3. Adjust the tension of the belt so that it can be about 2cm bent inward when you press the middle of it.  
Adjust the height of the motor to do this.
4. Install the belt cover referring to the Figure.

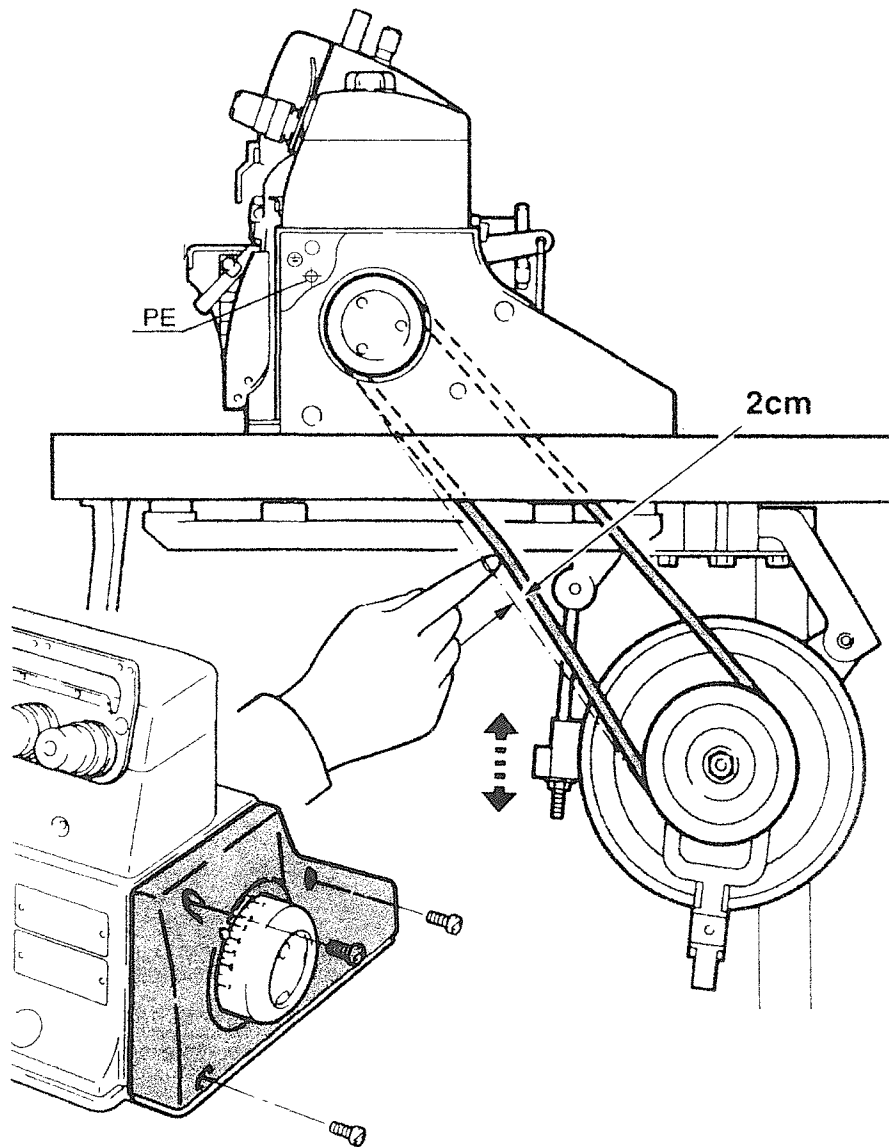

---

## ■ BEFORE OPERATING

The machine speed and the turning direction

The machine rotates clockwise when seen from the machine pulley side.

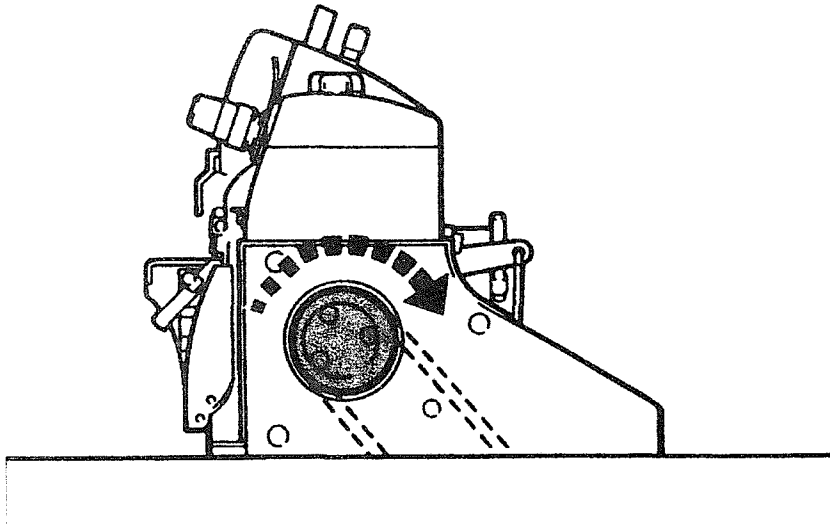

Make sure your machine type and run it not exceeding the maximum speed as listed in the table.

Machine model	The highest speed(r. p. m)
GM700-508	6, 500
GM700-5	6, 500
GM700-507	5, 500
GM700-504	6, 500
GM700-502	5, 500
GM700-302	7, 000
GM700-4	6, 500
GM700-304	6, 000
GM700-3	7, 000

## ■ BEFORE OPERATING

### Lubrication

After filling the oil pan, the oil surface should lie between (H) and (L) lines.

Add oil when the oil surface reaches or goes below (L).

Note : Use recommended oil (HIGH SPEED SEWING MACHINE OIL) (ISO VG22)

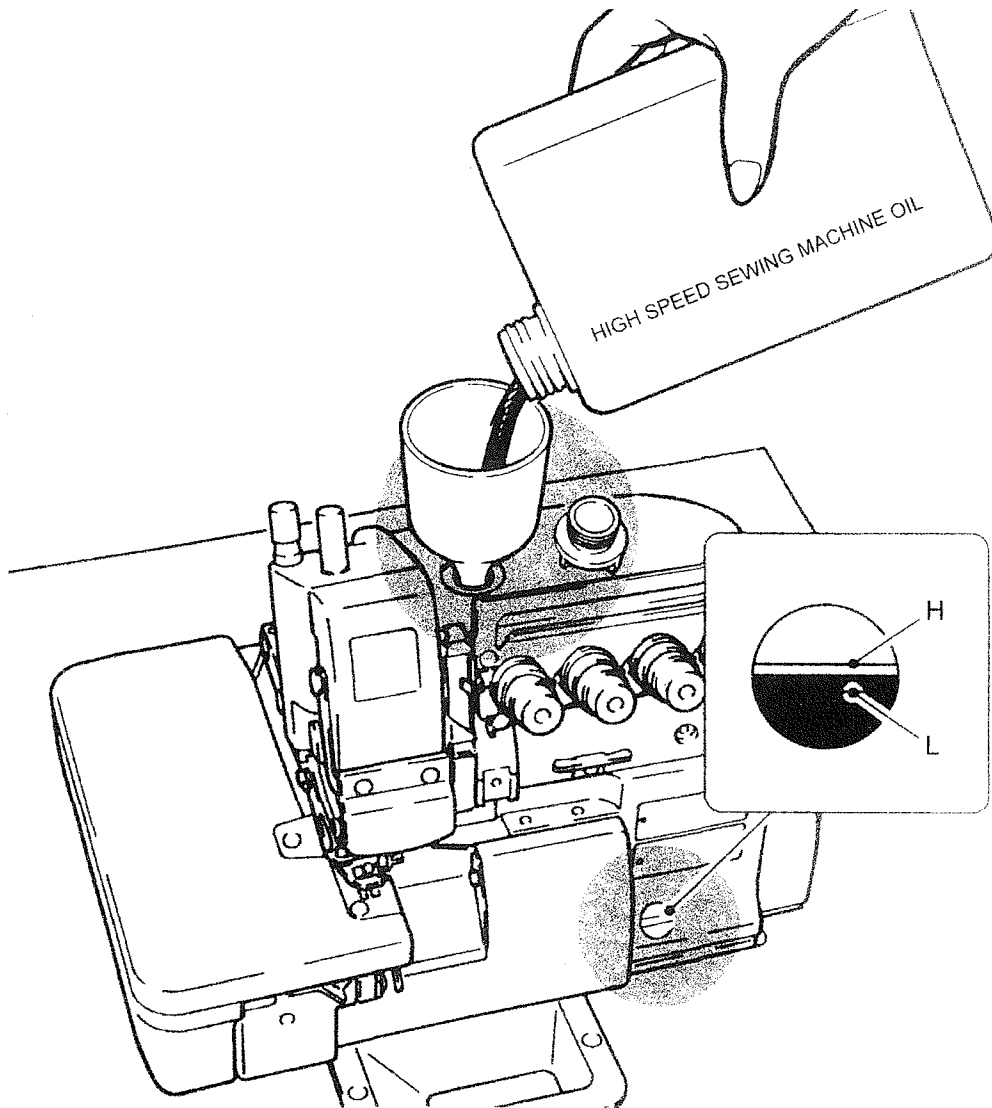



---

## ■ BEFORE OPERATING

### Manual lubrication

Apply 2 or 3 drops of oil by hand when the machine is used for the first time or has been left unused for some time.

Note : Use recommended oil (HIGH SPEED SEWING MACHINE OIL) (ISO VG22)

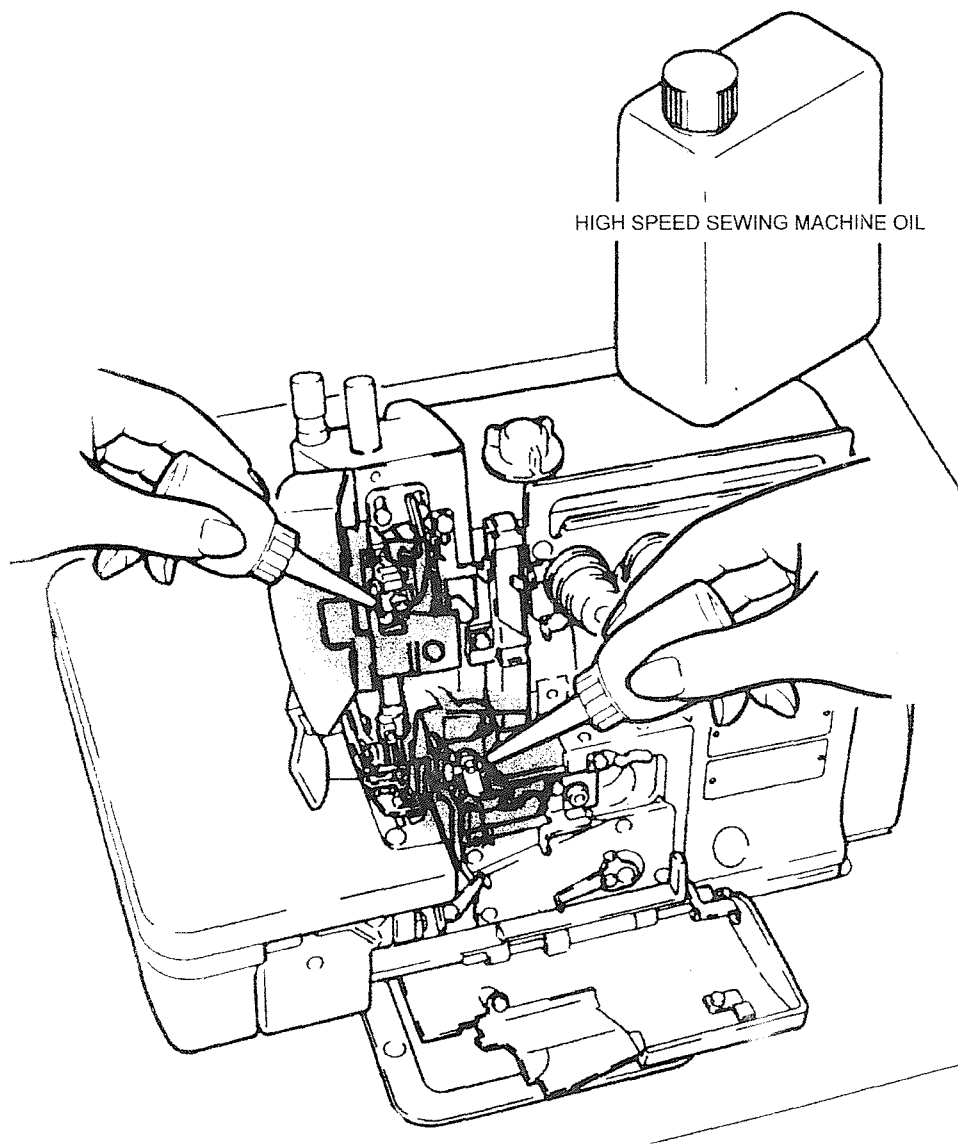

---

## ■ BEFORE OPERATING

### Filling the HR device with silicon oil

Fill the HR device with oil before it is too low in order to prevent needle thread breakage and fabric damage.

Note : Use recommended silicon oil

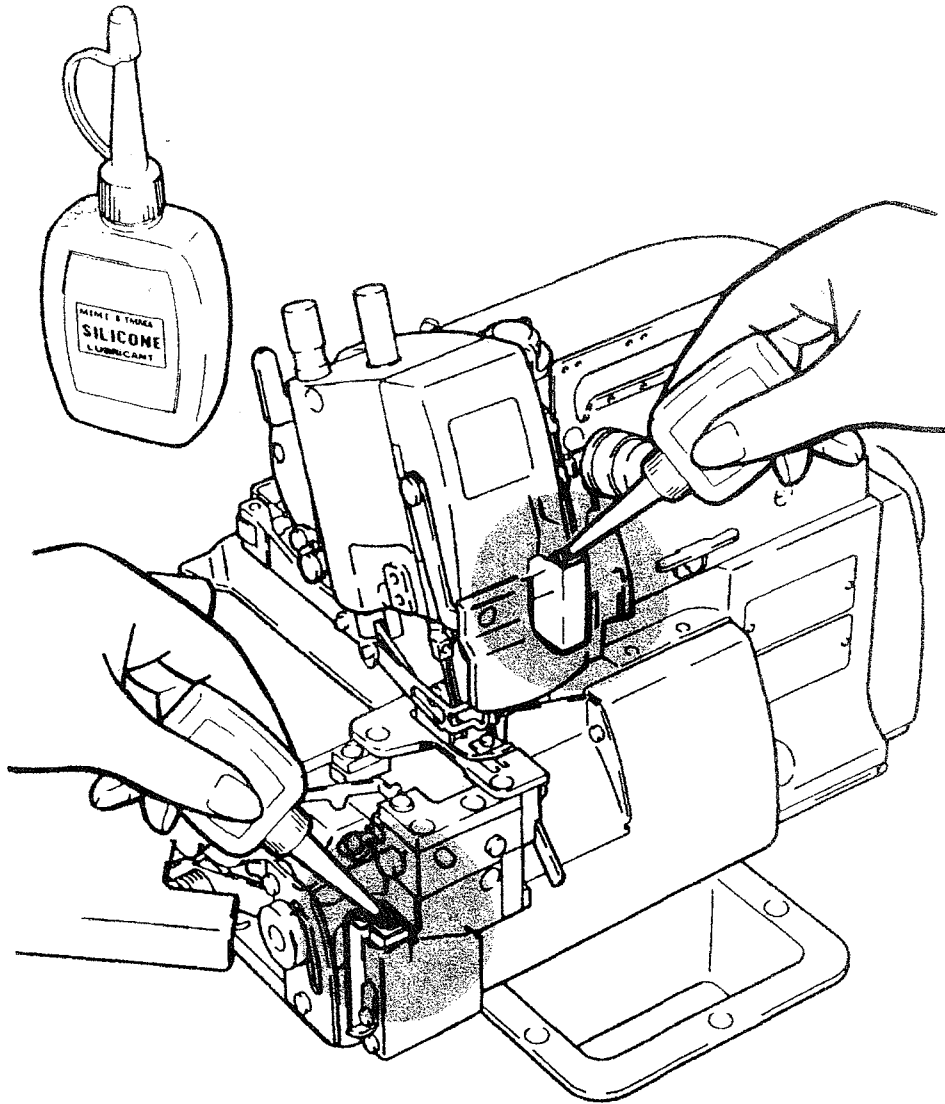

## ■ BEFORE OPERATING

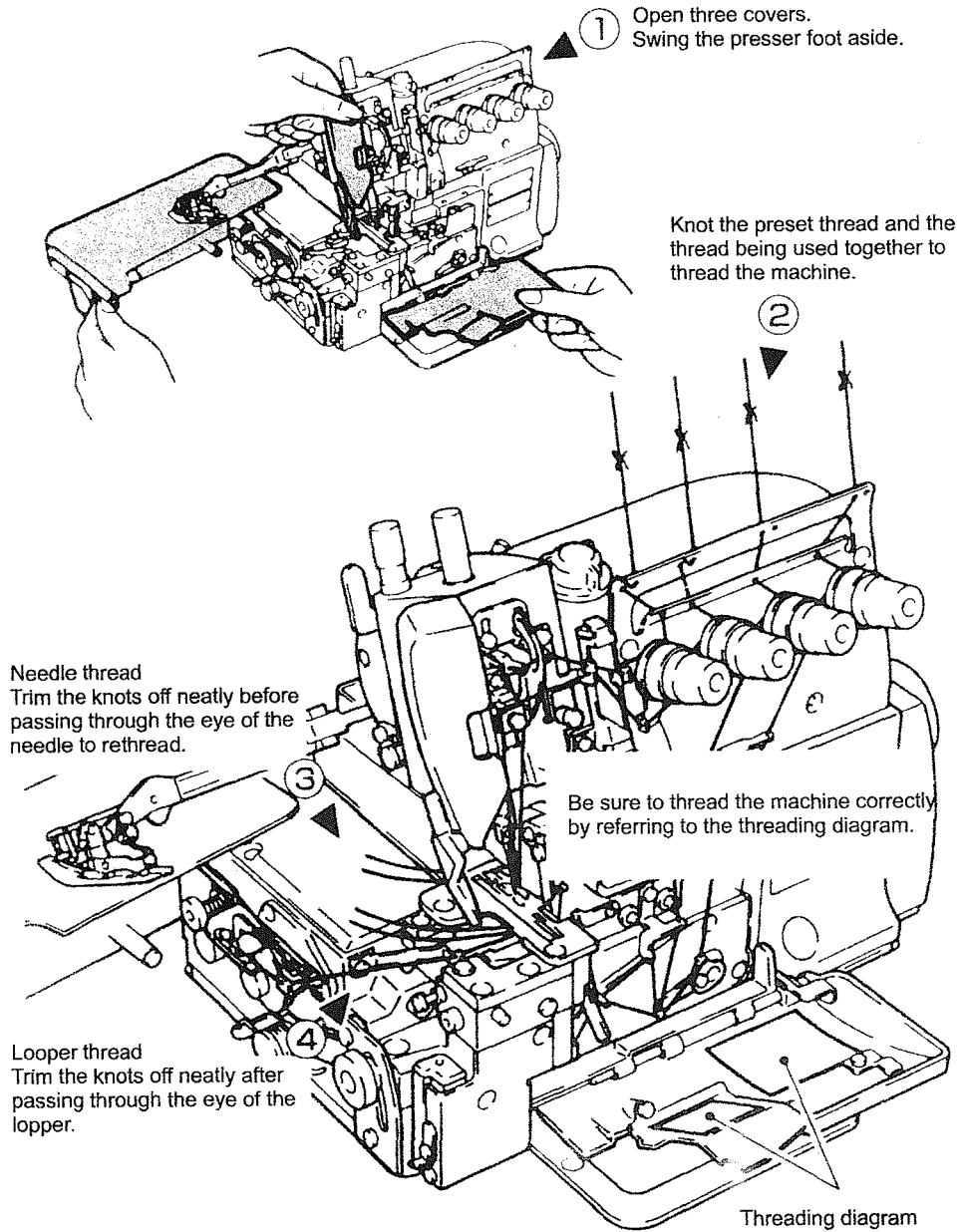

---

## ■ TEST SEWING

### Adjusting the presser foot pressure

Turn adjusting screw to adjust the presser foot pressure. It should be as light as possible, yet be sufficient to obtain the proper stitch formation.

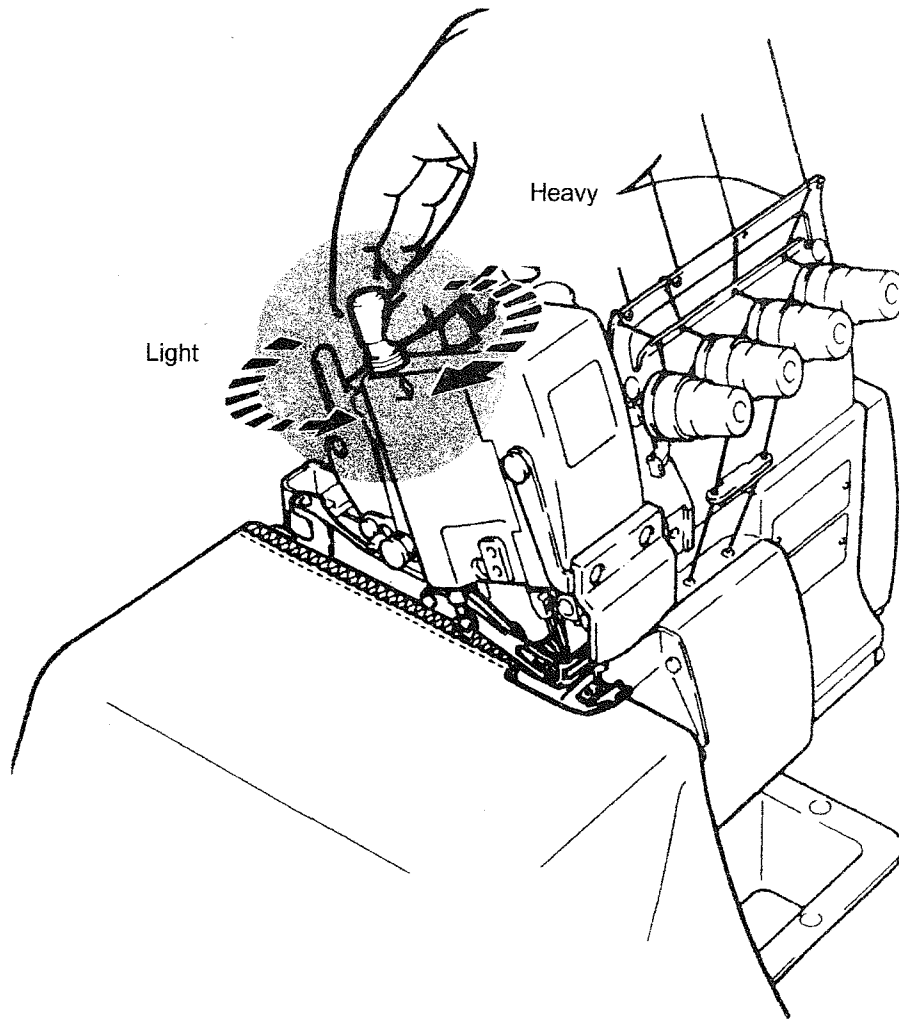

---

■ TEST SEWING

Adjusting the diff. feed ratio

Loosen the nut and move the lever up and down to obtain the correct differential feed ratio.  
Tighten the nut after positioning the lever as desired.

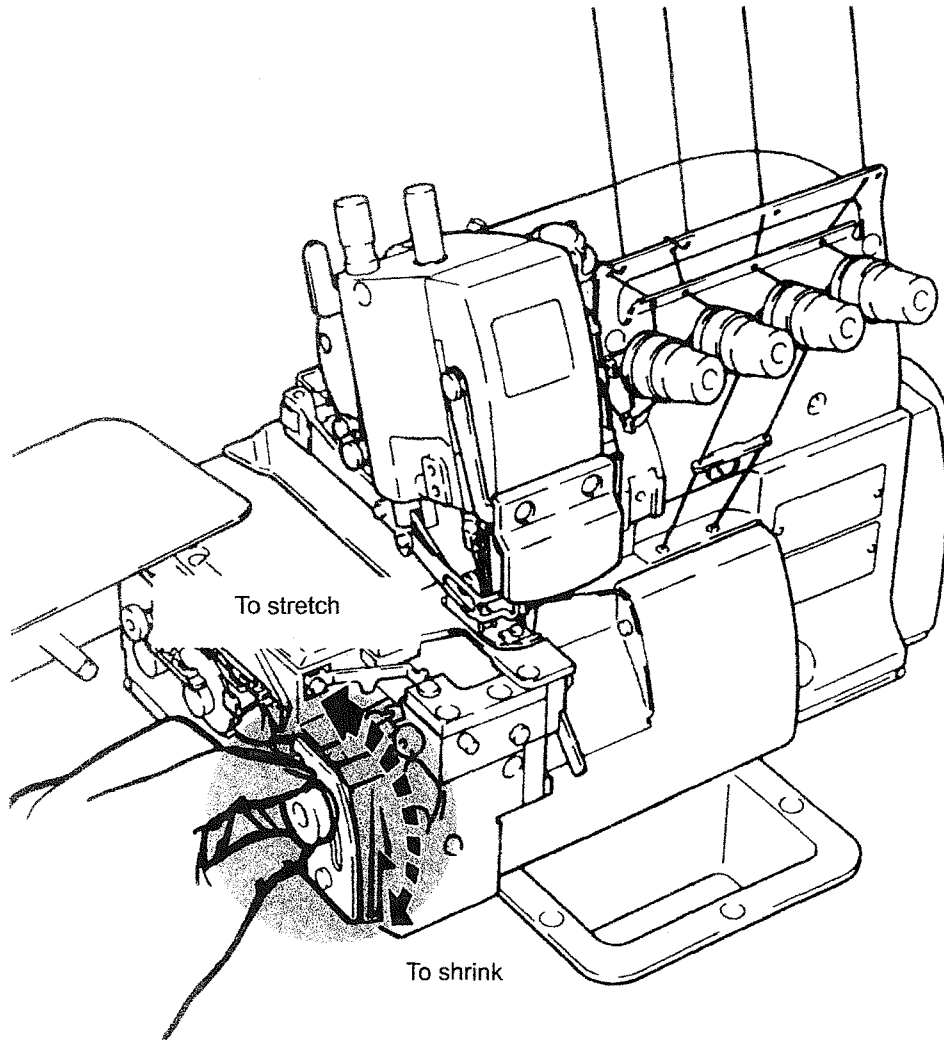

## ■ TEST SEWING

### Adjusting the stitch length

1. While pressing the push button, turn the hand wheel to seek the position at which the push button goes further into the depth.
2. Then, keeping the push button pressed, turn the hand wheel and, set the desired scale to the aligning mark.

Note : Stitch length adjustment must only be made after the differential feed ratio has been changed.

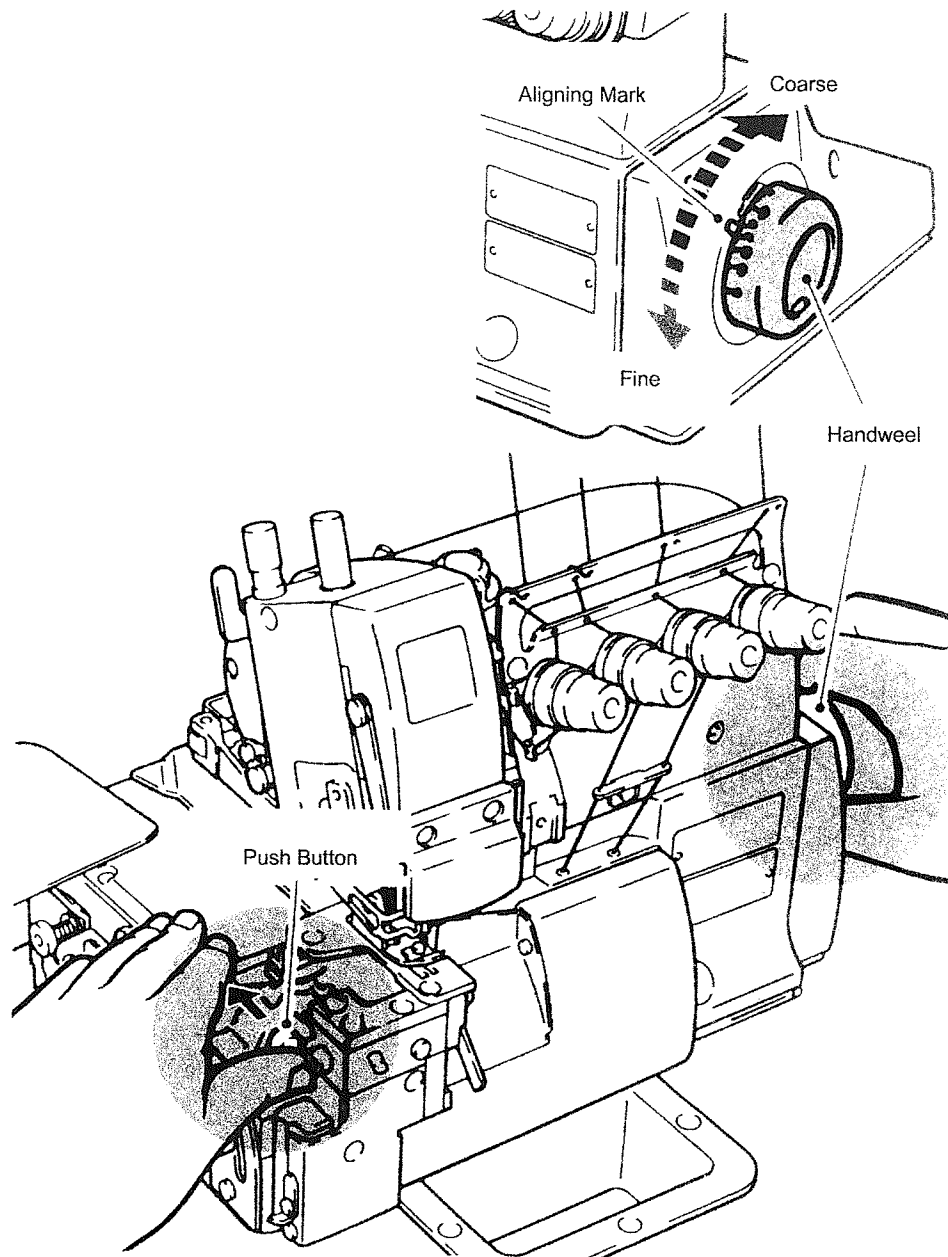

## ■ TEST SEWING

### Adjusting the thread tension

Make tension adjustments with the needle thread knob ① the upper looper knob ② and the lower looper knob ③.

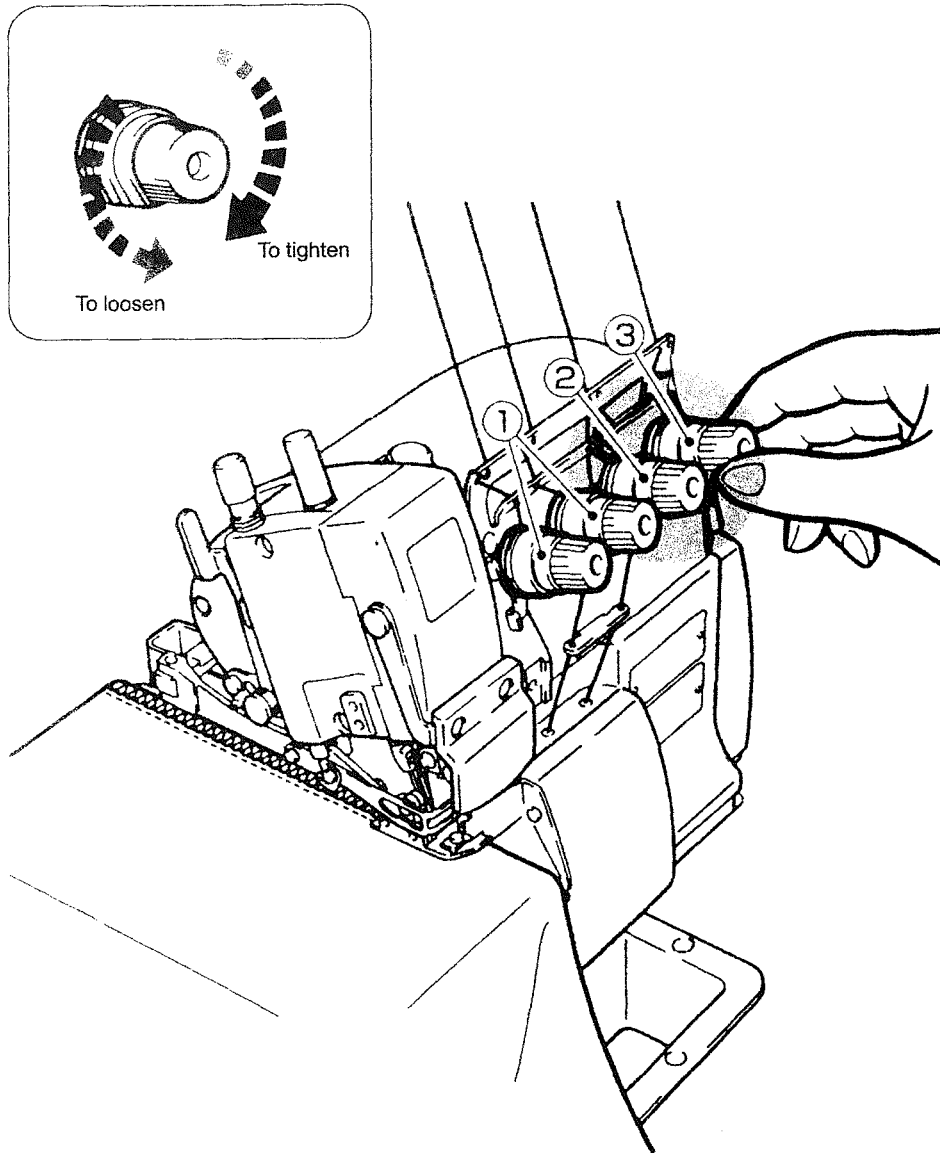

---

## ■ MAINTENANCE DURING USE

### Cleaning the machine

Mainly the slots of the needle plate and the feed rows should be cleaned.

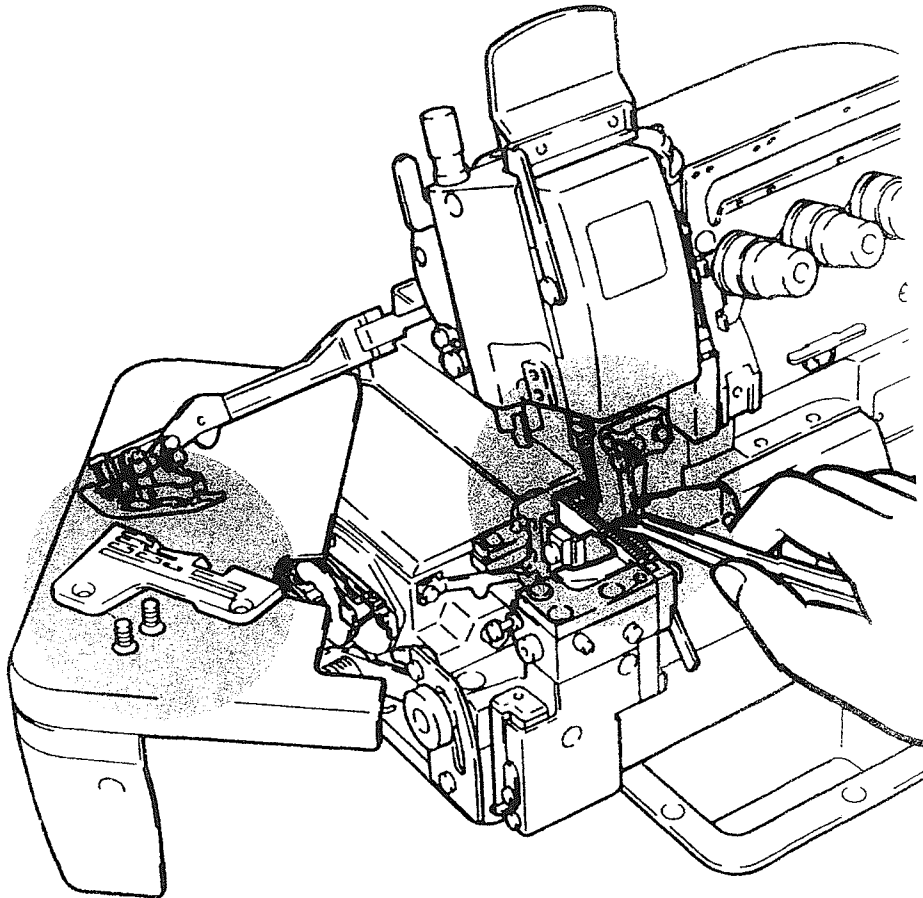



## ■ MAINTENANCE DURING USE

### Replacing the needle

Check the needle carefully to see that the scarf is to the rear of the machine.  
Insert the needle to the proper depth, and fasten securely.

Be sure to use standard needle. Refer to ADJUSTMENT DIMENSIONS on the end of instructions.

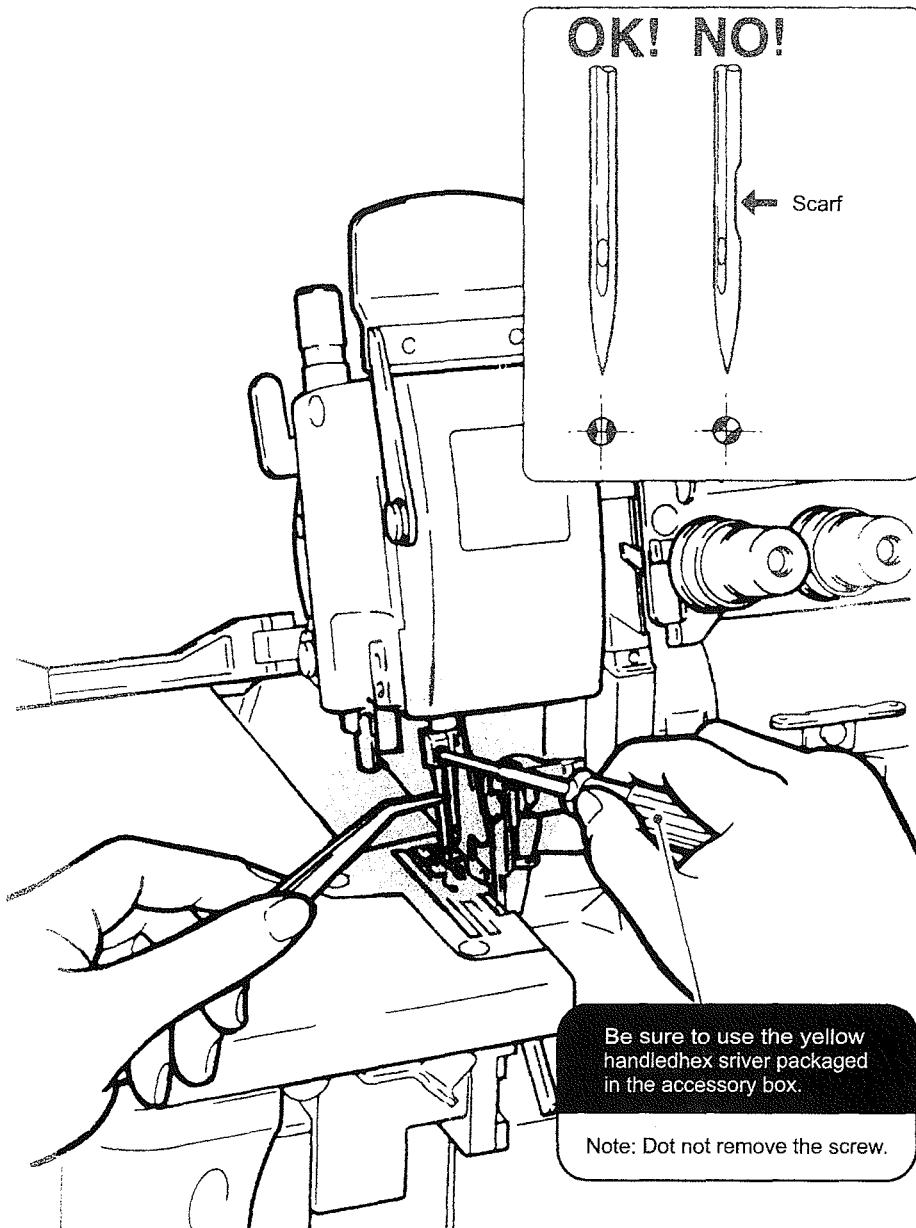

---

■ **MAINTENANCE DURING USE**

Checking the oil circulation

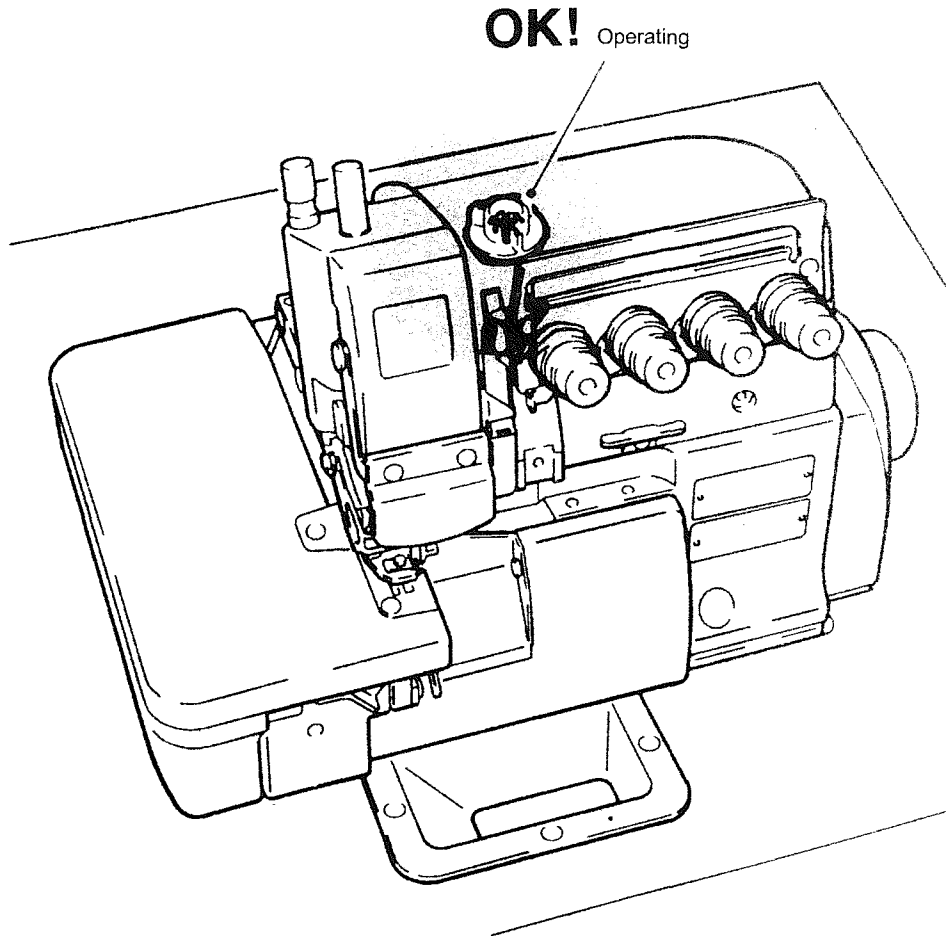

---

■ MAINTENANCE DURING USE

Replacing the oil

Replace the oil one month after the first use and every six months thereafter. (See P5)

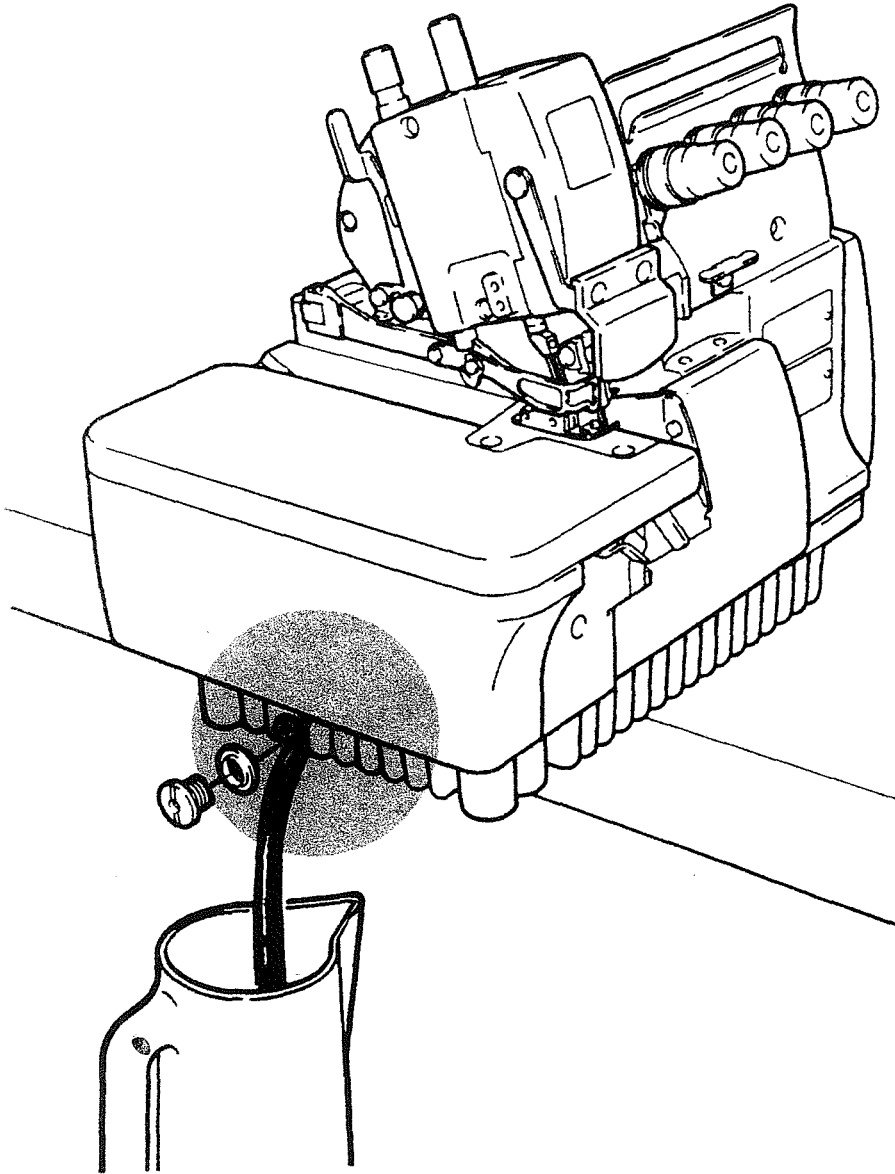

■ MAINTENANCE DURING USE

Replacing the lower knife

To remove the lower knife

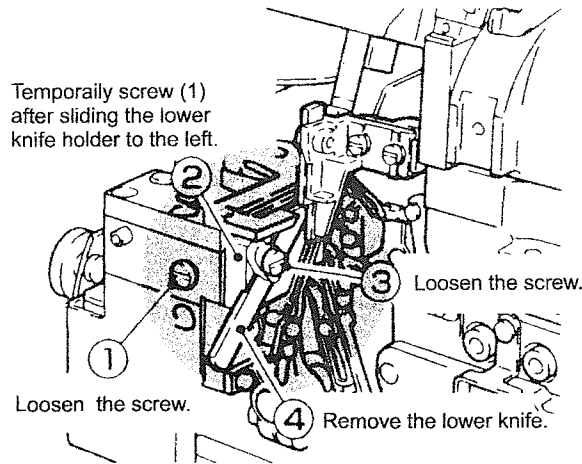

Correct angles to sharpen the lower knife

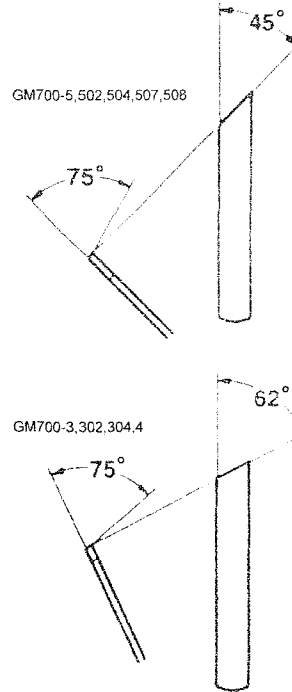



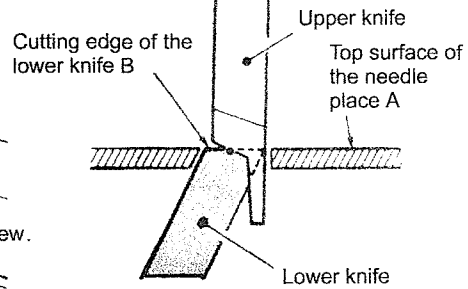
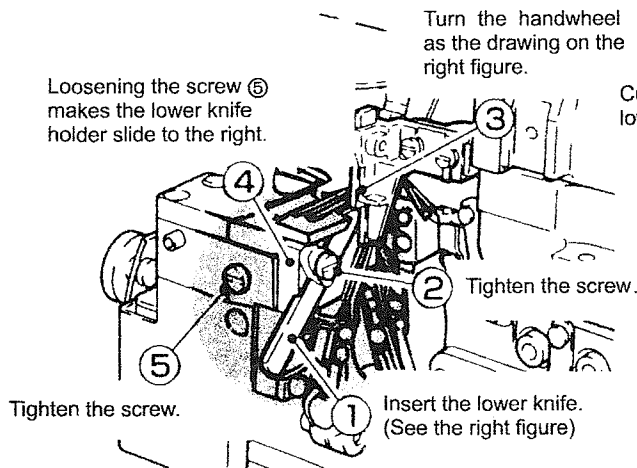



To replace the lower knife







Level of (A) = Level of (B)  
 Check cutting action of knives.

• GM700-5, 502, 504, 507, 508 Adjustment dimensions (mm)

						
GM700-508	10.6	3.9	3.3	0.9~1.1	5.5	1.5
GM700-5	10.6	3.9	3.3	0.9~1.1	5.5	1.5
GM700-507	10.1	3.9	3.3	0.9~1.1	5.5	1.5
GM700-504	10.6	3.9	3.3	0.9~1.1	5.5	1.5
GM700-502	12.0	3.4	3.3	0.9~1.1	5.5	1.5

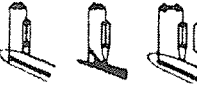
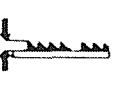
• GM700-3, 302, 304 Adjustment dimensions (mm)

					
GM700-302	10.1	4.2	3.3	0.9~1.1	5.5
GM700-4	10.1	4.6	4.0	0.9~1.1	5.5
GM700-304	10.1	4.2	3.3	0.9~1.1	6.0
GM700-3	10.1	4.2	3.3	0.9~1.1	5.5

• GM700-5, 502, 504, 507, 508 Standard needle

	Organ DCX27
GM700-508	11
GM700-5	14
GM700-507	14
GM700-504	14
GM700-502	21

• GM700-3, 302, 304, 4 Standard needle

	Organ DCX27
GM700-302	9
GM700-4	9
GM700-304	11
GM700-3	9

• GM700-5, 502, 504, 507, 508 • GM700-3, 302, 304, 4 Comparison table of equivalent sizes

Japanese size (Organ)	#	9	11	14	16	18	21
Chinese size (Organ)	Nm	65	75	90	100	110	130

---

# HIGH-SPEED OVERLOCK SEWING MACHINE

## • PARTS CATALOG •

1

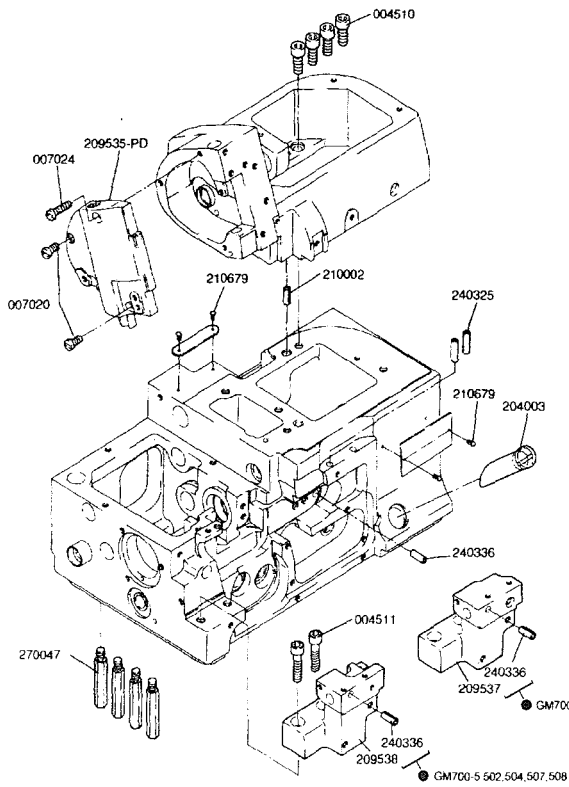

2

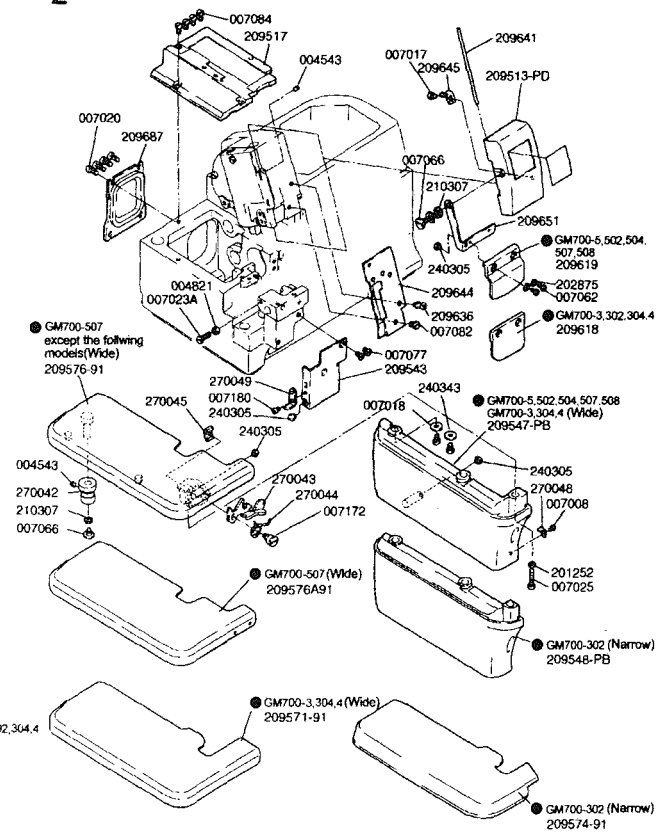

3

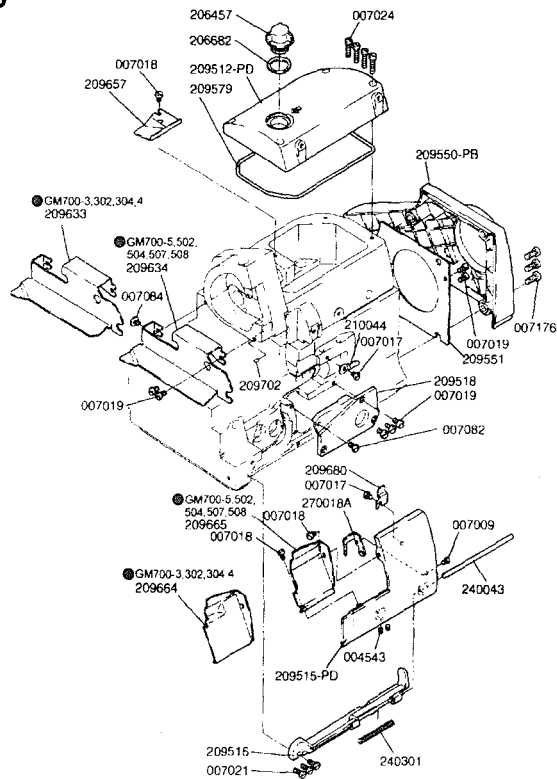

4

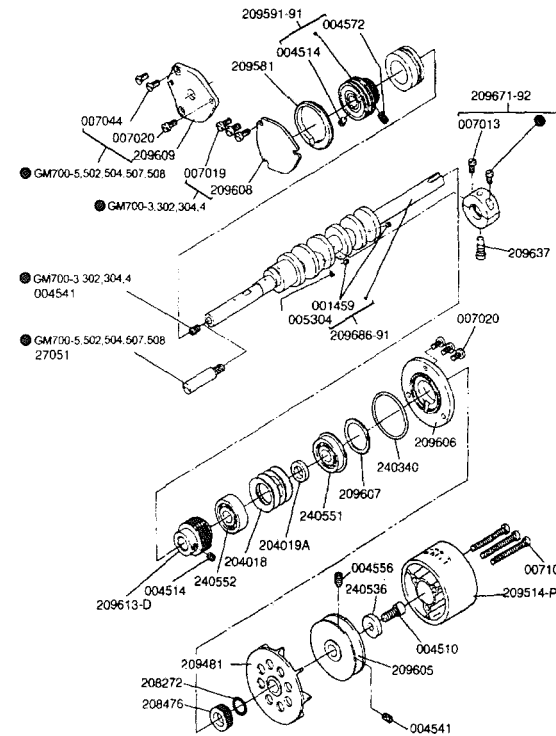

5 Please confirm the correct part by the gauge parts lists.

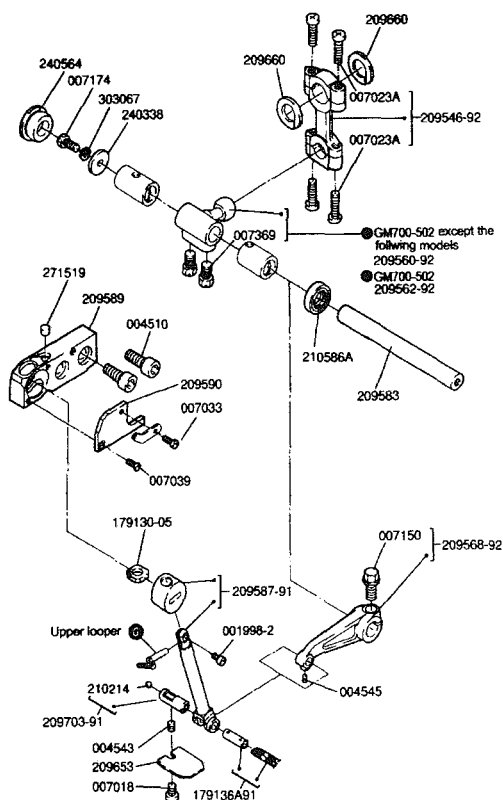

6 Please confirm the correct part by the gauge parts lists.

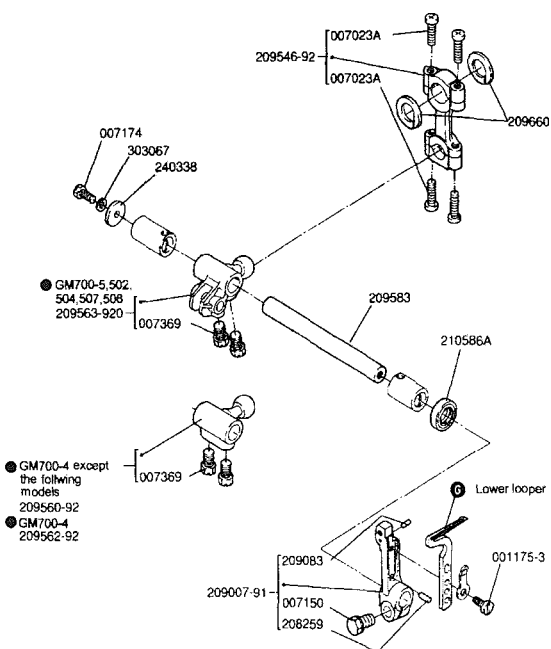

7 Please confirm the correct part by the gauge parts lists.

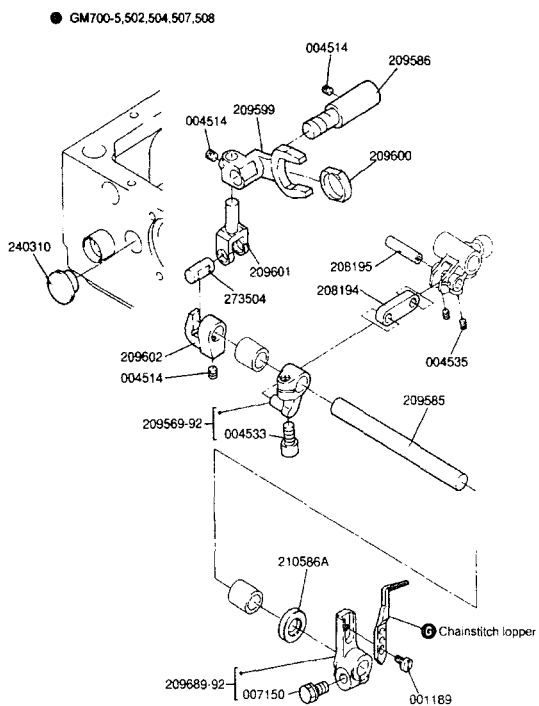

8 Please confirm the correct part by the gauge parts lists.

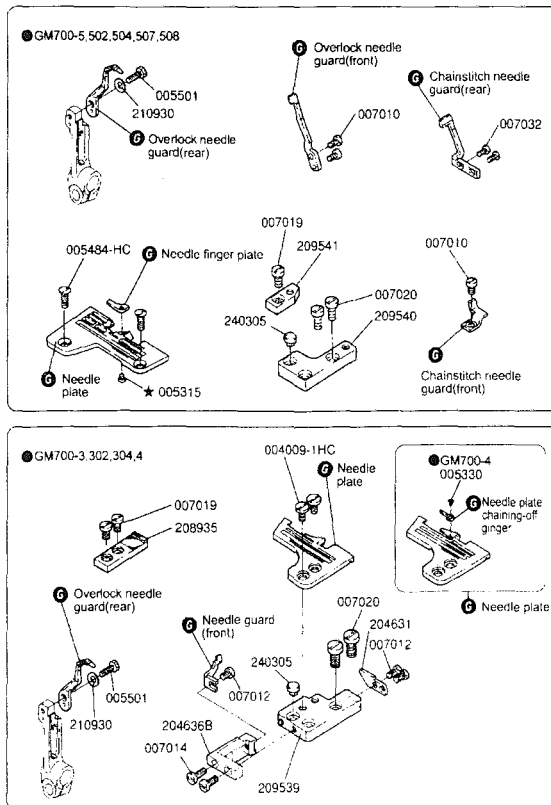



**9** Please confirm the correct part by the gauge parts lists.

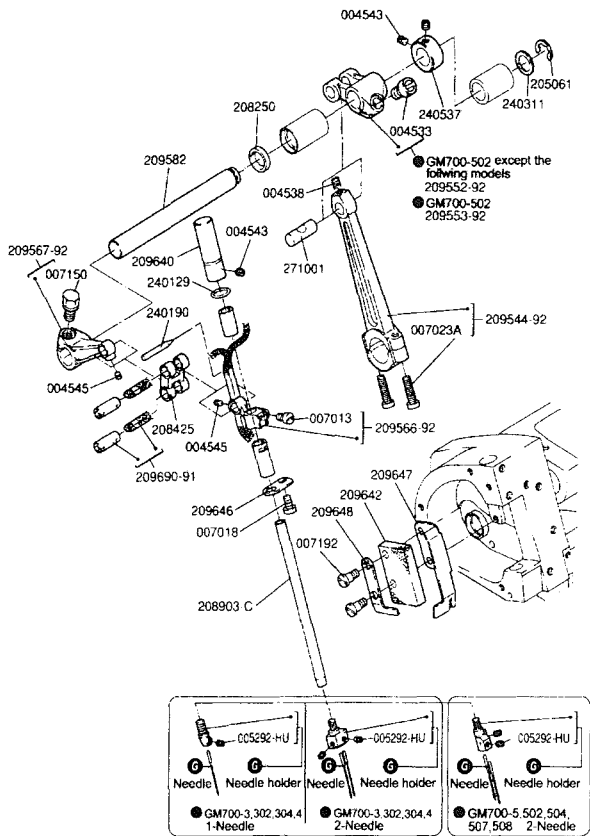

**10** Please confirm the correct part by the gauge parts lists.

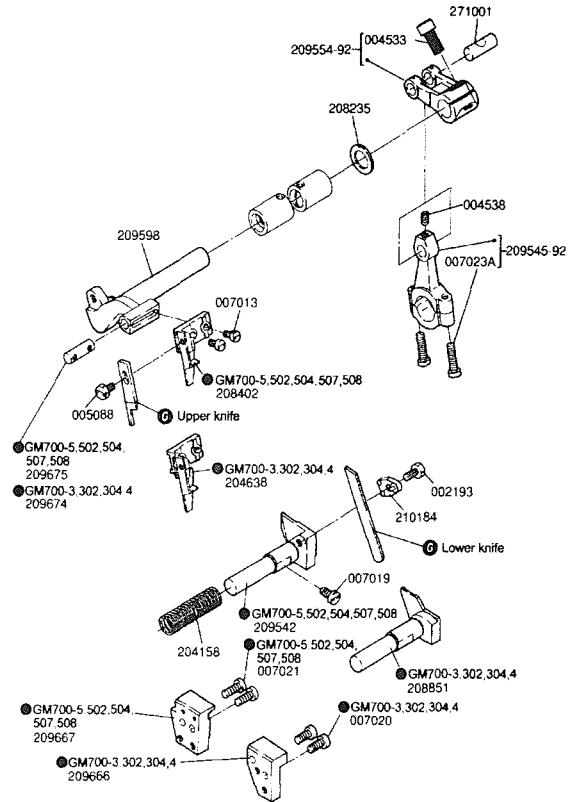

**11** Please confirm the correct part by the gauge parts lists.

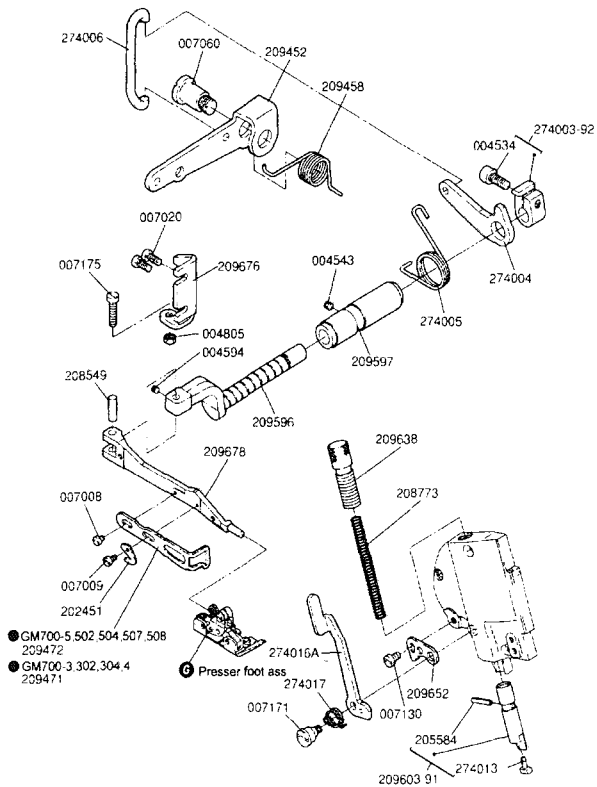

**12** Please confirm the correct part by the gauge parts lists.

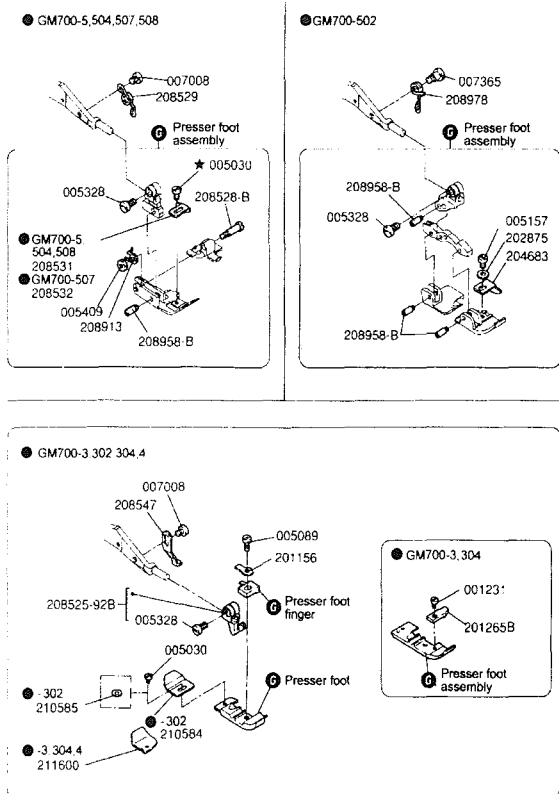

13

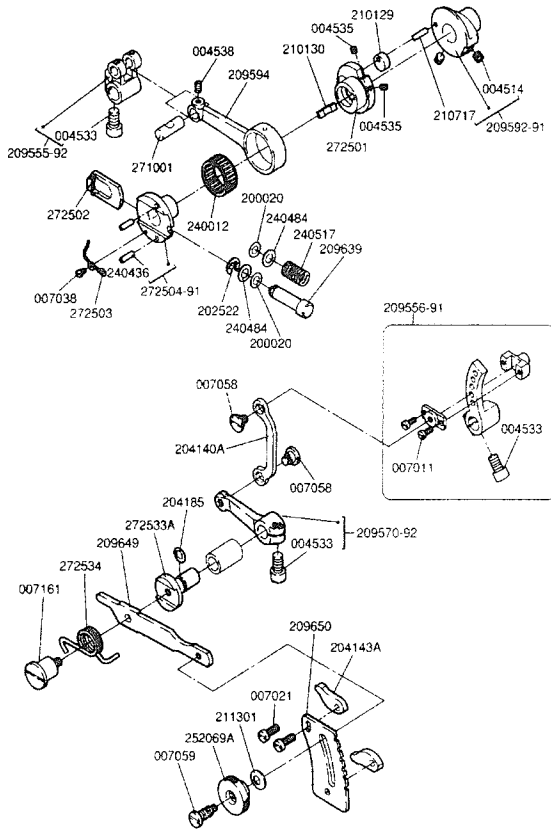

14 ☉ Please confirm the correct part by the gauge parts lists.

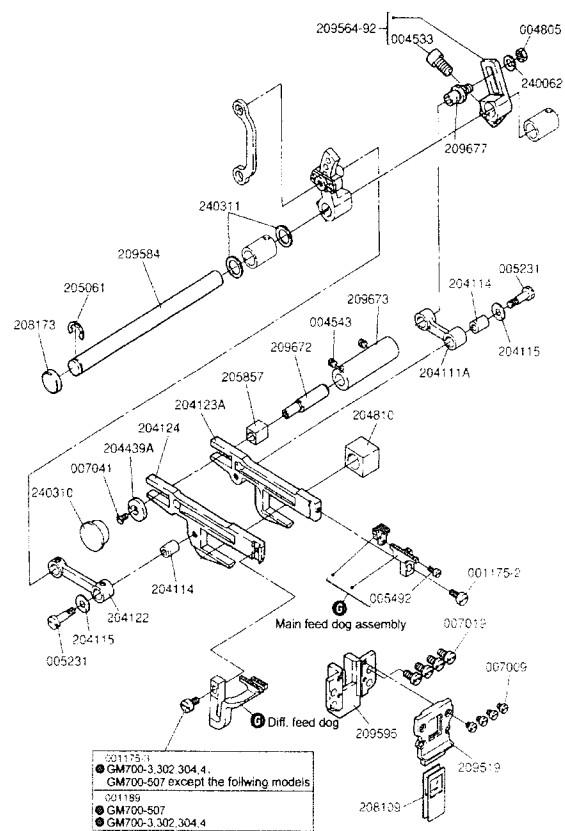

15

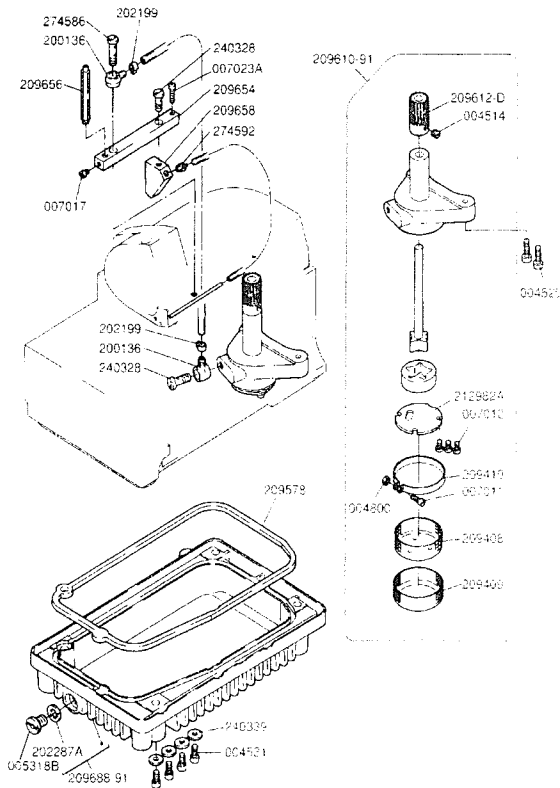

16

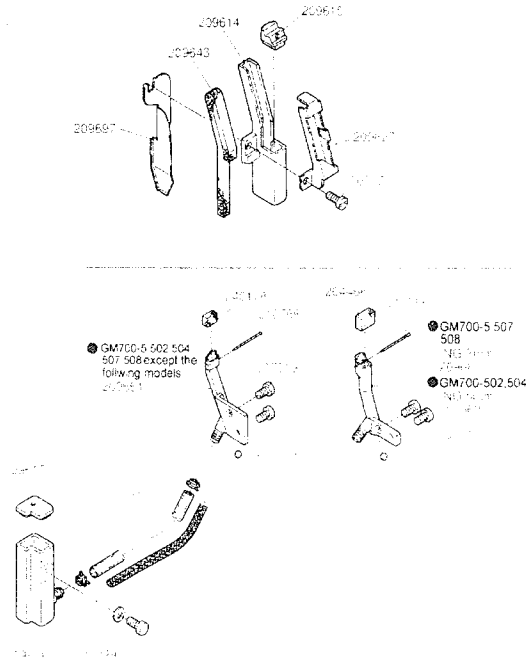

17

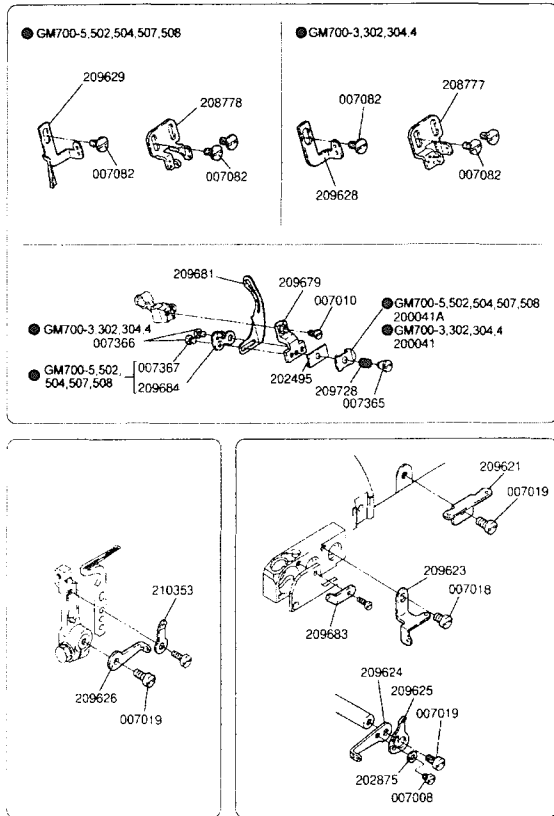

18 Please confirm the correct part by the gauge parts lists.

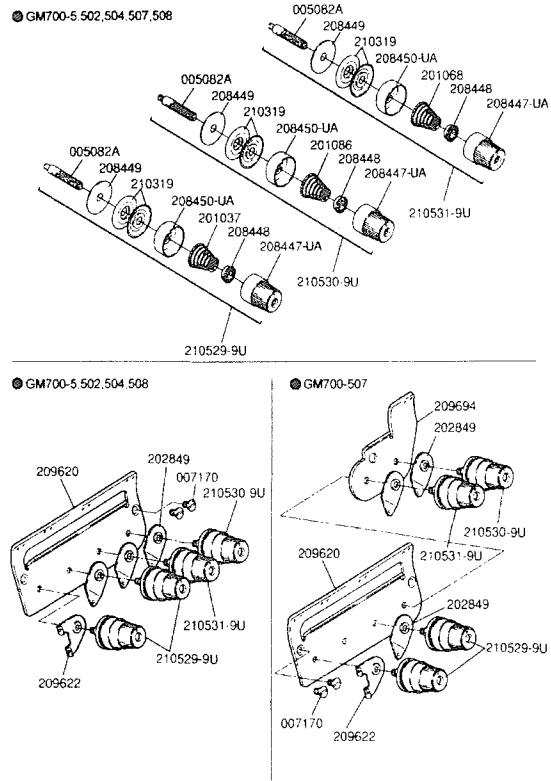

19

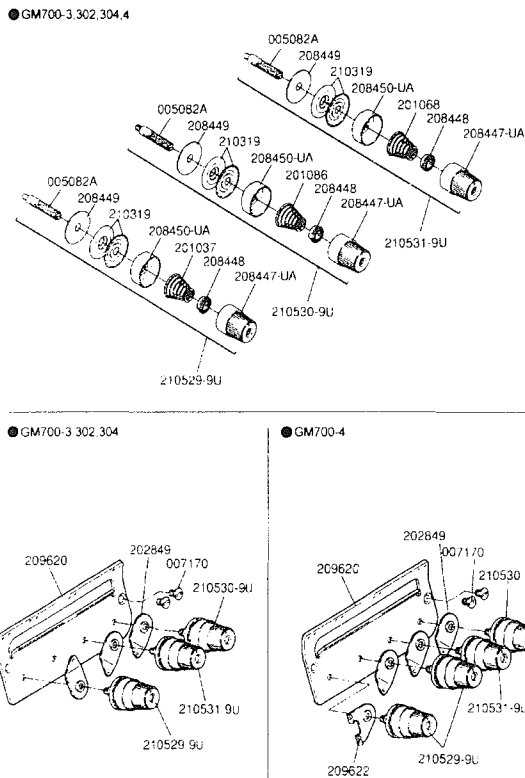

20

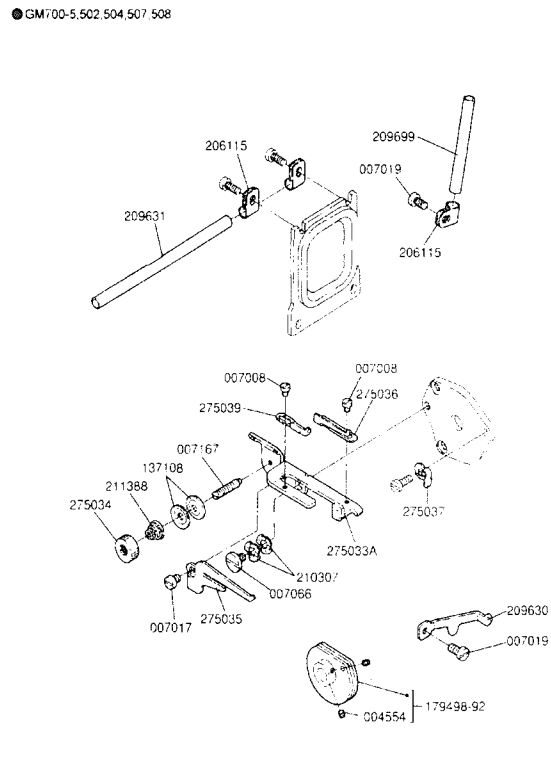

# 21

Blind hemming  
● GM700-302

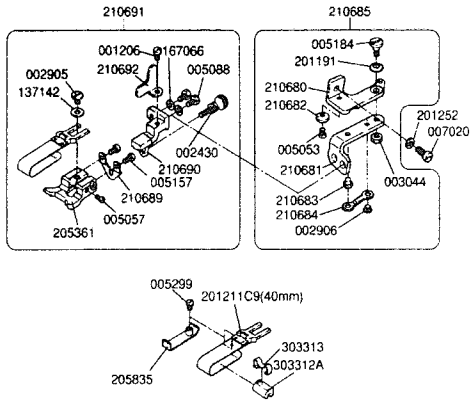

Attaching tape  
● GM700-4

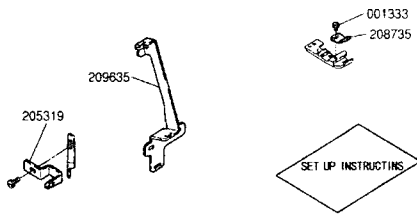

# 22

Shirring  
● GM700-507

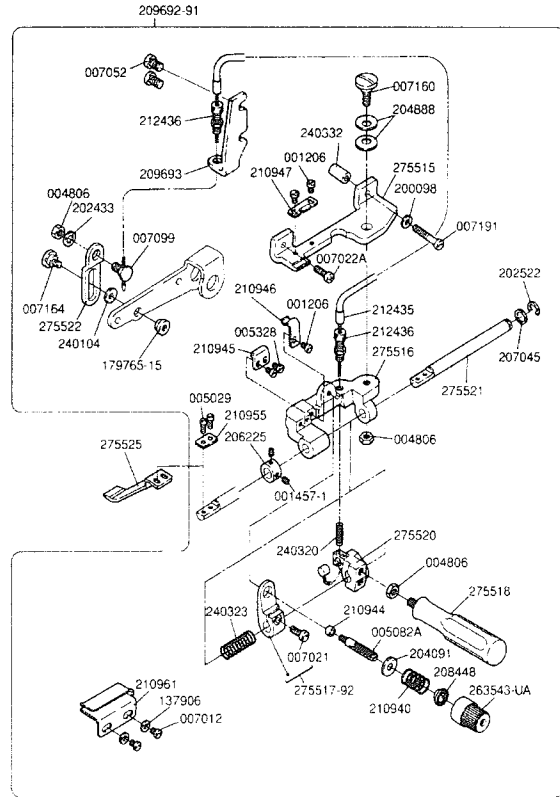

# 23

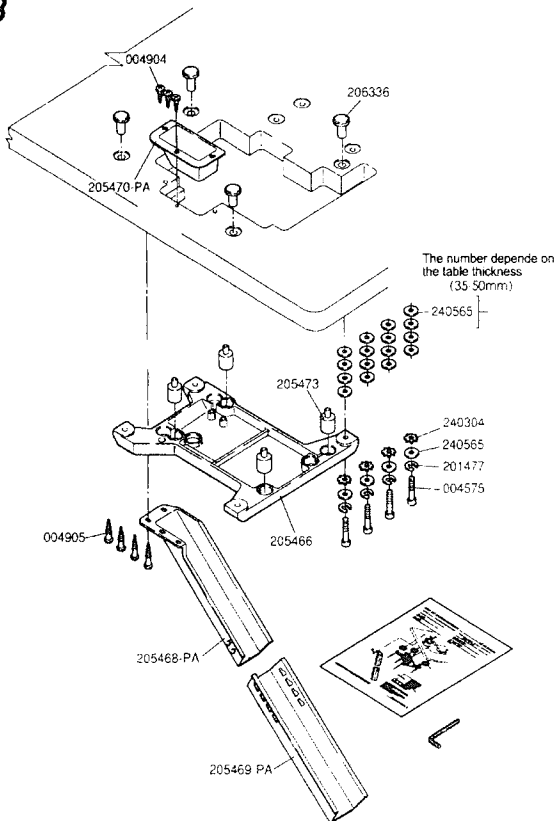

# 24

Ⓢ Please confirm the correct part by the gauge parts lists.

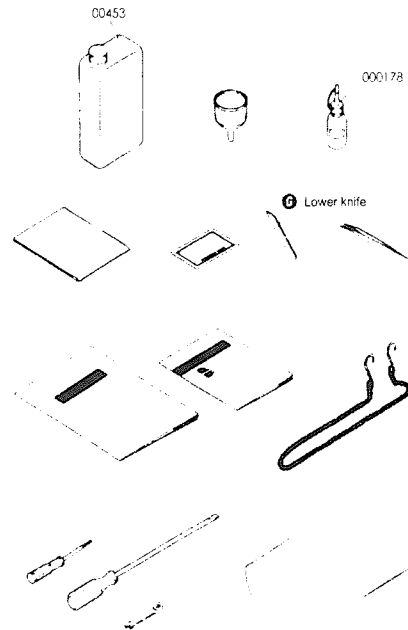

25

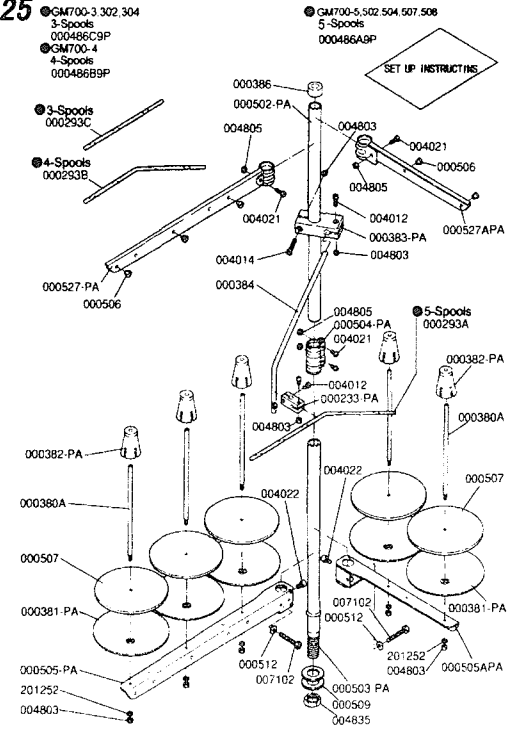

GM700-5, 502, 504, 507, 508 GAUGE PARTS LIST



MACHINE TYPE/SPEC	GAUGE NG	SW	NEEDLE PLATE	NEEDLE FINGER PLATE	MAIN FEED DOG ASS.	MAIN FEED DOG	AUX. FEED DOG	DIFF. FEED DOG	PRESSER FOOT ASS.	UPPER LOOPER	LOWER LOOPER	CHAINSTITCH LOOPER
GM700-508	3	4	204367	210505	208065	(204395)	(204425)	208218	208501	204062	204072	209685
GM700-5	3	4	204367	210505	208066	(204396)	(208060)	208219	208501	204702	204072	209685
GM700-507	3	4	204940	210505	208074	(204931)	(208061)	204420	208508	204702	204072	209685
GM700-504	5	5	204360A	210506	208063	(204248B)	(208059)	208215	208502	204702	204072	209685
GM700-502	5	6	204529	210509	208064	(204394)	(208059)	208217	208955	204703	204072	209685-HC



MACHINE TYPE/SPEC	GAUGE NG	SW	UPPER KNIFE	LOWER KNIFE	OVERLOCK NEEDLE		CHAINSTITCH NEEDLE		NEEDLE HOLDER	NEEDLE
					FRONT	REAR	FRONT	REAR		
GM700-508	3	4	201121A	204161	209668	209009	204536	209669	208909B92	DCX27#11
GM700-5	3	4	201121A	204161	209668	209009	204536	209669	208909B92	DCX27#14
GM700-507	3	4	201121A	204161	209668	209009	204536	209669	208909B92	DCX27#14
GM700-504	5	5	201121A	204161	209668	209009	204042	209669A	208910B92	DCX27#14
GM700-502	5	6	201121A	204161	209668	209009	204042	209669A	208910B92	DCX27#21

GM700-3, 302, 304, 4 GAUGE PARTS LIST



MACHINE TYPE/SPEC	GAUGE NG	SW	NEEDLE PLATE	MAIN FEED DOG ASS.	MAIN FEED DOG	AUX. FEED DOG	DIFF. FEED DOG	PRESSER FOOT	PRESSER FOOT FINGER	UPPER LOOPER	LOWER LOOPER
GM700-302	-	4	205773	208090-BF	(204729ABF)	(204674)	204730-BF	201152E	201155C	204062	204072
GM700-4	2	4	202554E	208078-BF	(204675ABF)	(204674)	204676-BF	208730	208732	204949	204072
GM700-304	-	1.5	205465	208911	(204729A)	(208912)	204730	201230C	205525	204062	204072
GM700-3	-	4	202546E	208078-BF	(204675ABF)	(204674)	204676-BF	201230C	210371	204062	204072



MACHINE TYPE/SPEC	GAUGE NG	SW	UPPER KNIFE	LOWER KNIFE	NEEDLE GUARD		NEEDLE HOLDER	NEEDLE
					FRONT	REAR		
GM700-302	-	4	201121A	202295	2046259	209009	209670-92	DCX27#9
GM700-4	2	4	201121A	202295	2046259	209009	208905A92	DCX27#9
GM700-304	-	1.5	201121A	202295	2046259	209009	209670-92	DCX27#11
GM700-3	-	4	201121A	202295	2046259	209009	209670-92	DCX27#9



**SHANGHAI HUIGONG NO.3 SEWING MACHINE FACTORY**

**ADD: 1418, Yishan Road, Shanghai, China**

**Zip Code: 201103**

**Overseas Business: TEL: 86-21-64853303 FAX: 86-21-64854304**

**E-mail: [highlead@online.sh.cn](mailto:highlead@online.sh.cn) <http://www.highlead.com.cn>**

The description covered in this manual is subject to change for improvement of the commodity without notice

2006.8. Printed